

SPECIFICATION SUBMITTAL SHEET

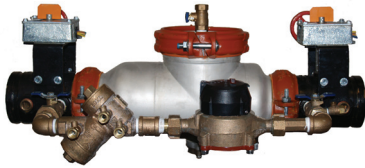

FEATURES

Sizes: 2 1/2" 3" 4" 6" 8" 10"

Maximum working water pressure 175 PSI
 Maximum working water temperature 140°F
 Hydrostatic test pressure 350 PSI
 End connections (Grooved for steel pipe) AWWA C606
 (Flanged) ANSI B16.1
 Class 125

OPTIONS

(Suffixes can be combined)

- with flanged end OS & Y gate valves (standard)
- LM - less water meter
- with remote reading meter
- with gallon meter (standard)
- CFM - with cu ft meter
- CMM - with cu meter meter
- G - with grooved end OS&Y gate valves
- FG - with flanged inlet gate connection and grooved outlet gate connection
- PI - with Post Indicator Gate Valves (4"-10")
- BGVIC - with grooved end butterfly valves with integral supervisory switches

ACCESSORIES

- Repair kit (rubber only)
- Thermal expansion tank (Model XT)
- OS & Y Gate valve tamper switch (OSY-40)
- Test Cock Lock (Model TCL24)

DIMENSIONS & WEIGHTS (do not include pkg.)

MODEL 350ASTDA SIZE		WEIGHT					
		WITH OS&Y GATES (GXF)		WITH OS&Y GATES (GXG)		WITH BUTTERFLY VALVES (GXG)	
in.	mm	lbs.	kg	lbs.	kg	lbs.	kg
2 1/2	65	126	57	116	53	70	32
3	80	143	65	131	60	73	33
4	100	218	99	198	90	85	39
6	150	352	160	322	147	142	65
8	200	667	303	613	278	314	142
10	250	885	401	827	375	419	190

MODEL 350ASTDA SIZE		DIMENSION (approximate)																			
		A		A WITH BUTTERFLY VALVES		B LESS GATE VALVES		C		D		E OS&Y OPEN		E OS&Y CLOSED		E WITH BUTTERFLY VALVES		F		G	
in	mm	in	mm	in	mm	in	mm	in	mm	in	mm	in	mm	in	mm	in	mm	in	mm	in	mm
2 1/2	65	31 7/8	810	28 3/4	730	16 5/8	422	4 1/2	114	7 1/4	184	17 3/4	451	15 3/8	391	8	203	5	127	12	305
3	80	32 7/8	835	29 3/8	746	16 5/8	422	4 1/2	114	7 1/4	184	20 1/4	514	17	432	8	203	5	127	12	305
4	100	34 7/8	886	30 1/4	768	16 5/8	422	4 1/2	114	8	203	22 1/2	572	18 1/4	464	9 1/8	232	5	127	12	305
6	150	43 1/2	1105	36 1/2	927	22 1/4	565	5 1/2	140	10	254	30 1/2	775	24 1/4	616	10 1/8	257	6	152	10 1/2	267
8	200	52 3/4	1340	45 3/4	1162	29 1/2	749	9 1/4	235	11	279	37	940	28 1/2	724	18 1/2	470	8 3/8	213	15 1/8	384
10	250	55 3/4	1416	49 3/4	1264	29 1/2	749	9 1/4	235	12	305	45 5/8	1159	34 3/4	883	18 1/2	470	8 3/8	213	15 1/8	384

APPLICATION

Designed for installation on potable water lines connections in fire sprinkler systems to protect against both backsiphonage and backpressure of polluted water into the potable water supply. Model 350ASTDA shall provide protection where a potential health hazard does not exist. Incorporates metered by-pass to detect leaks and unauthorized water use.

STANDARDS COMPLIANCE (HORIZONTAL & VERTICAL)

- ASSE® Listed 1048
- AWWA Compliant C510 (with gates only) (2-1/2" to 6"), and C550
- UL® Classified
- C-UL® Classified
- FM® Approved
- CSA® Certified

MATERIALS

Main valve body 304L Stainless steel
 Access covers 304L Stainless steel
 Internals Stainless steel, 300 Series
 NORYL™, NSF Listed
 Fasteners & springs Stainless Steel, 300 Series
 Elastomers EPDM (FDA approved)
 Buna Nitrile (FDA approved)
 Polymers NORYL™, NSF Listed

MODEL 350ASTDA with OS&Y option

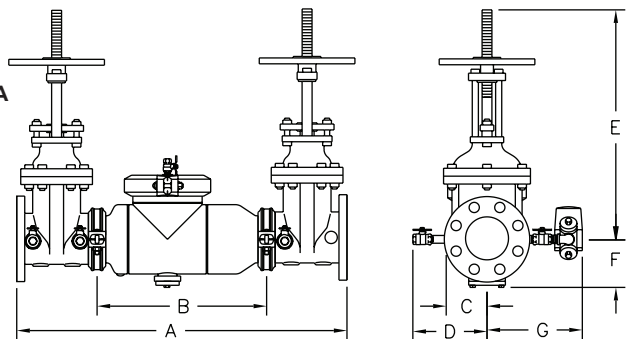

MODEL 350ASTDA with BGVIC option

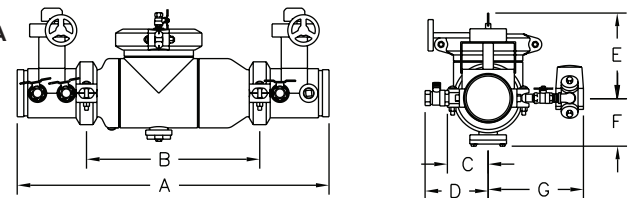

FLOW CHARACTERISTICS

MODEL 350ASTDA 2 1/2", 3" & 4" (STANDARD & METRIC)

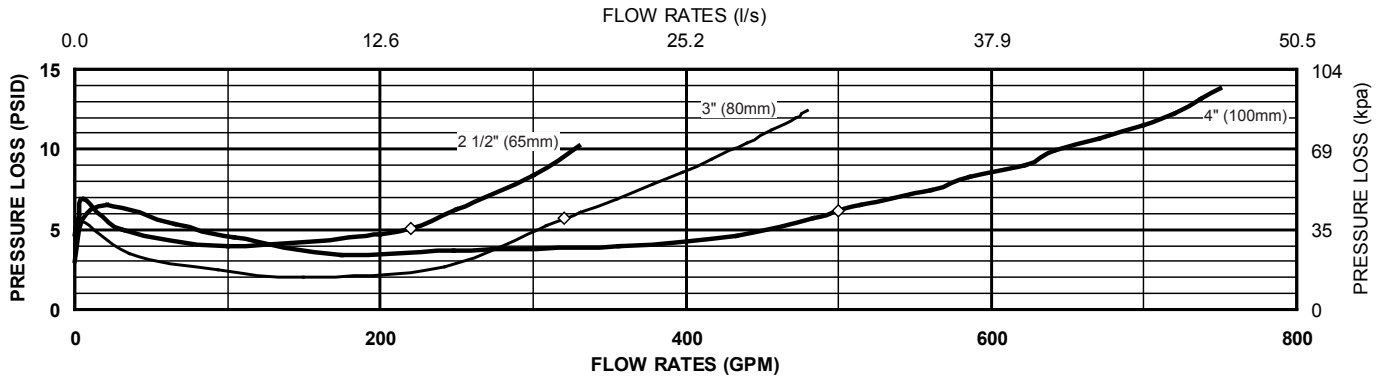

MODEL 350ASTDA 6" 8" & 10" (STANDARD AND METRIC)

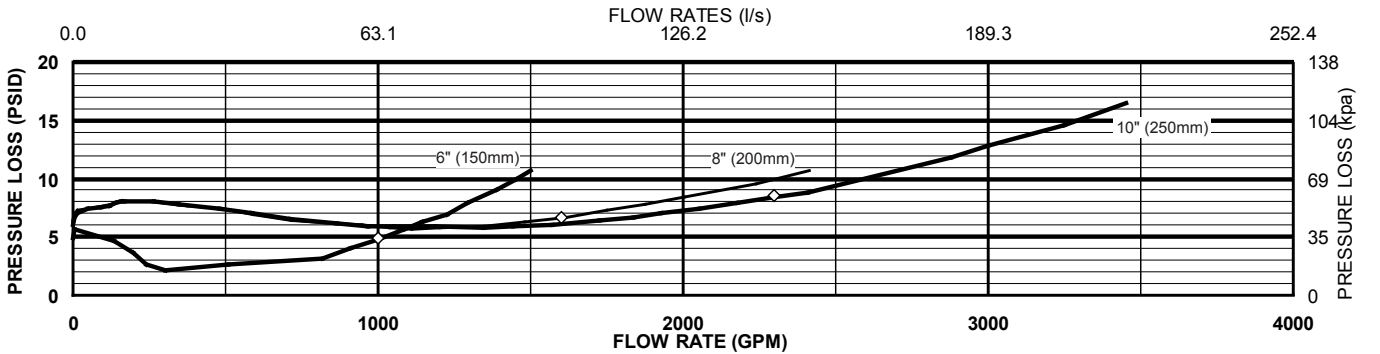

◇ Rated Flow (Established by approval agencies)

TYPICAL INSTALLATION

Local codes shall govern installation requirements. Unless otherwise specified, the assembly shall be mounted at a minimum of 12" (305mm) and a maximum of 30" (762mm) above adequate drains with sufficient side clearance for testing and maintenance. The installation shall be made so that no part of the unit can be submerged.

Capacity thru Schedule 40 Pipe (GPM)				
Pipe size	5 ft/sec	7.5 ft/sec	10ft/sec	15 ft/sec
2 1/2"	75	112	149	224
3"	115	173	230	346
4"	198	298	397	595
6"	450	675	900	1351
8"	780	1169	1559	2339
10"	1229	1843	2458	3687
12"	1763	2644	3525	5288

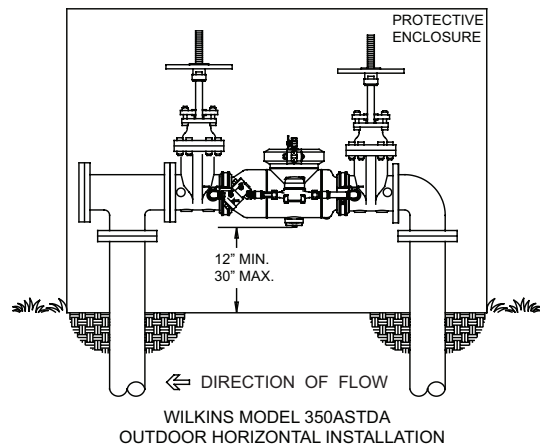
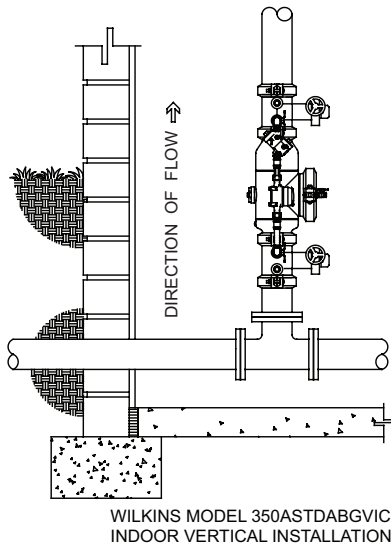

SPECIFICATIONS

The Double Check Detector Backflow Prevention Assembly shall be ASSE® Listed 1048, and supplied with full port gate valves. The main body and access cover shall be 304L Stainless Steel, the seat ring and check valve shall be Noryl™ (NSF Listed), the stem shall be stainless steel (ASTM A 276) and the seat disc elastomers shall be EPDM. The first and second check valves shall be accessible for maintenance without removing the device from the line. The Double Check Detector Backflow Prevention Assembly shall be a WILKINS Model 350ASTDA.